

Fingerboard Geography for Double Bass

in 1st and 3rd position

Key of D Major



The key of D Major has 2 sharps: F# and C#.

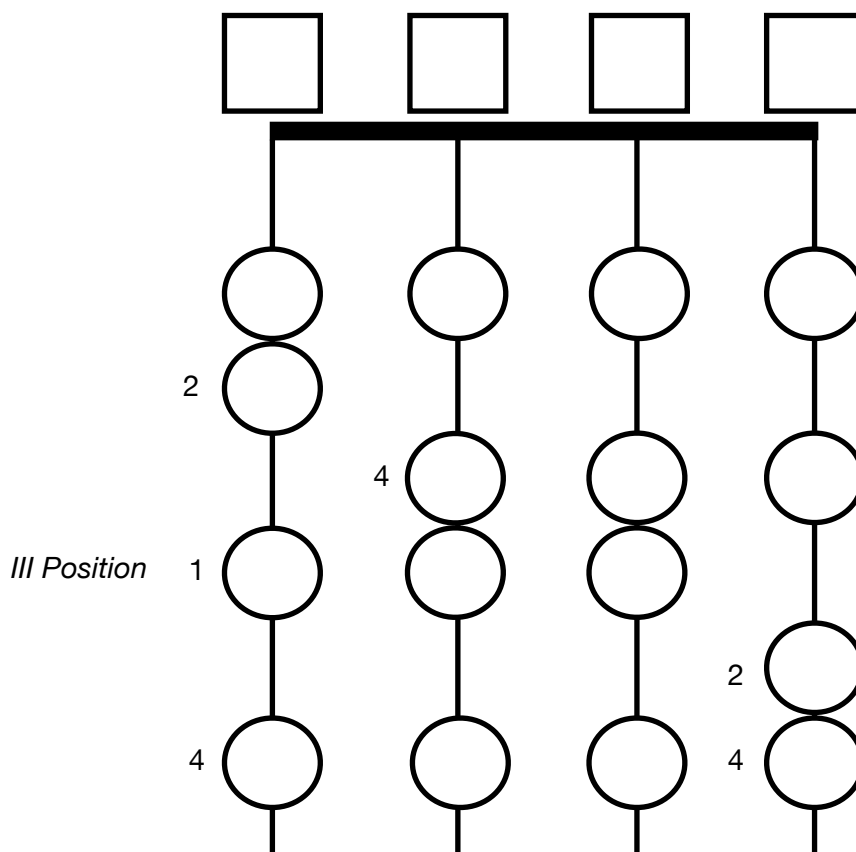

Key of G Major



The key of G Major has 1 sharp: F#.

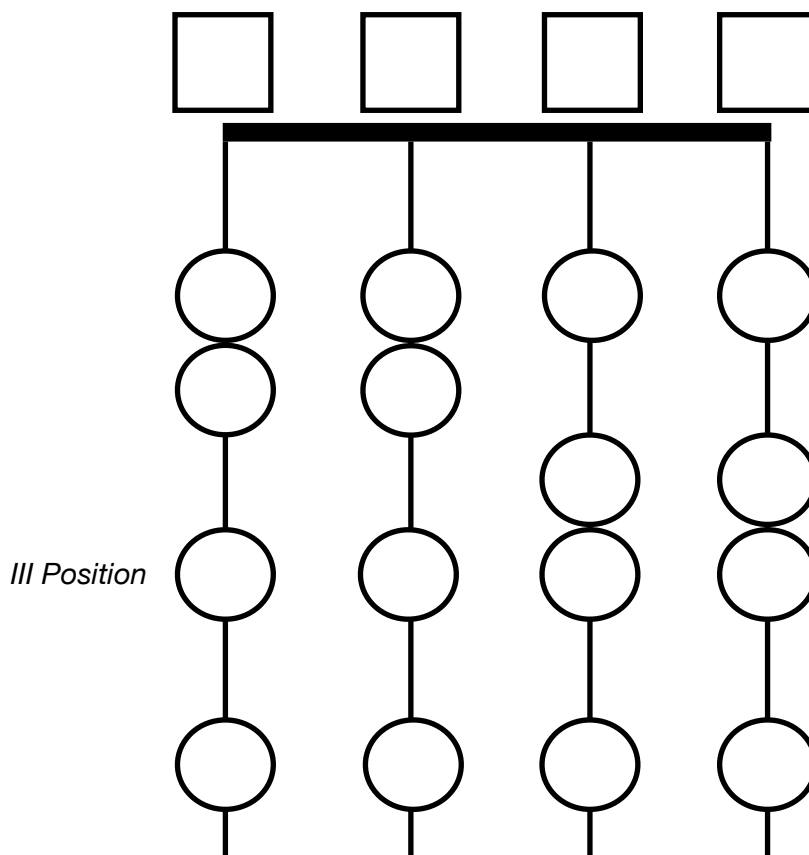

Fingerboard Geography for Double Bass

Key of D Major

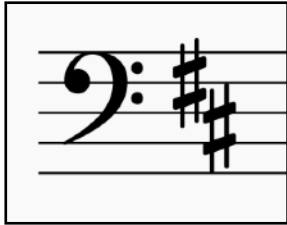

The key of D Major has 2 sharps: F# and C#.

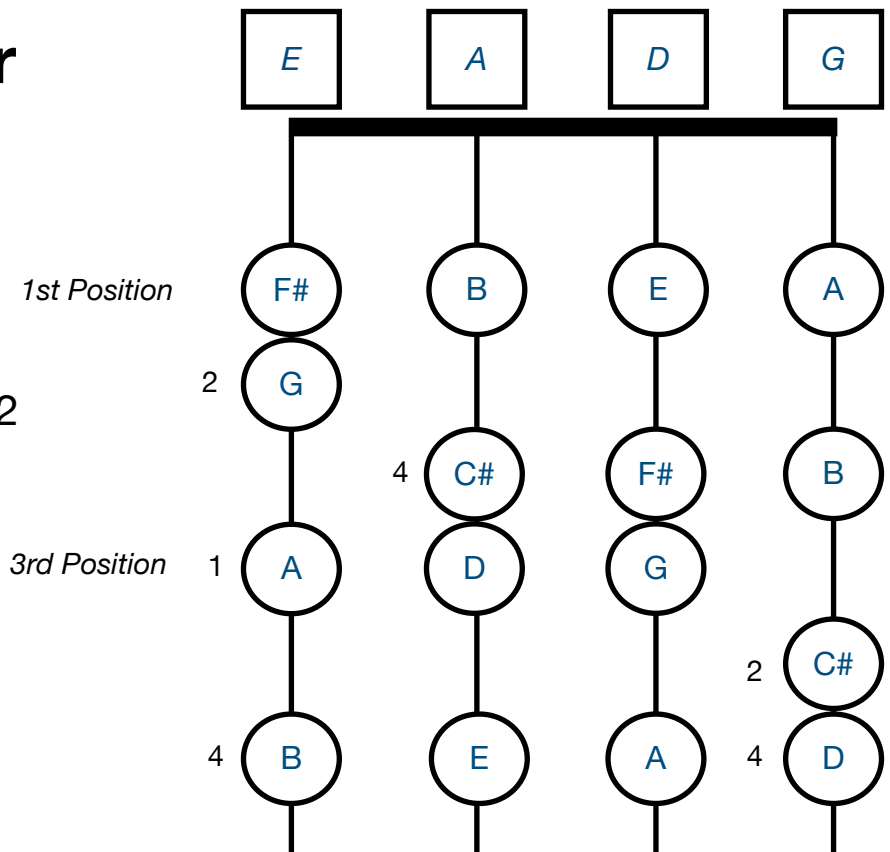

Key of G Major



The key of G Major has 1 sharp: F#.

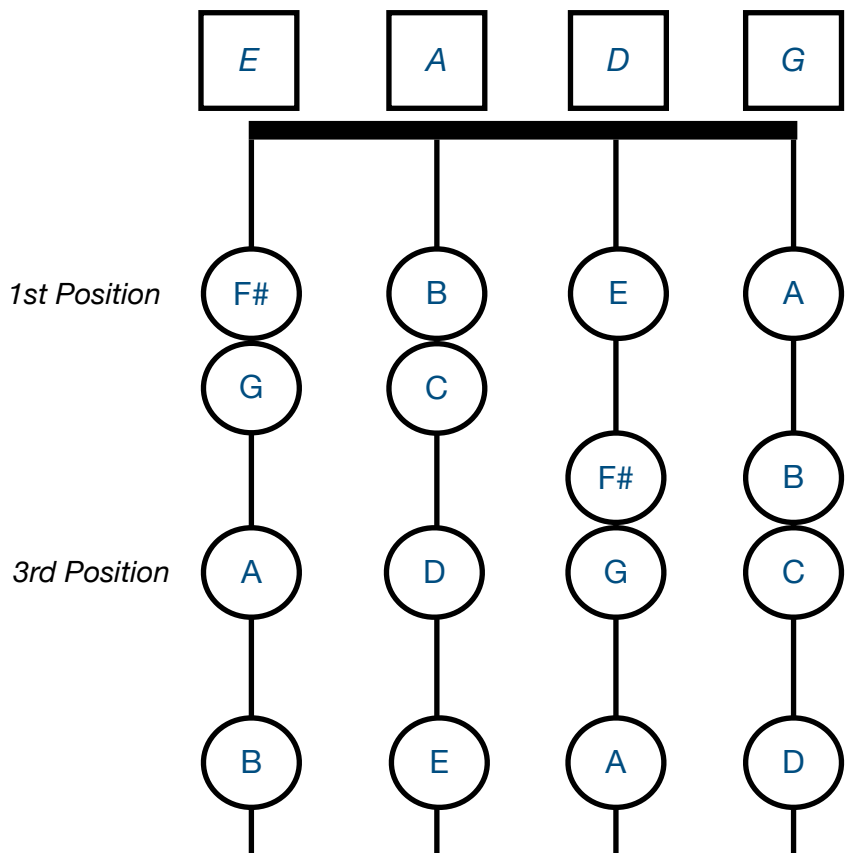

Fingerboard Geography for Double Bass

Key of C Major



The key of C Major has no sharps or flats.

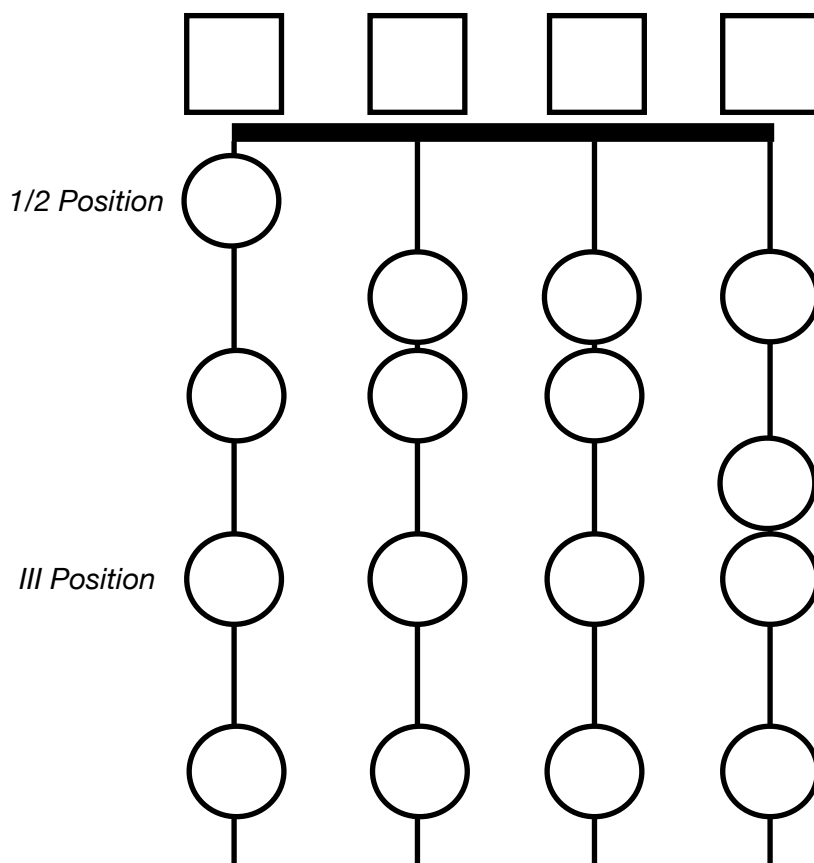

Key of F Major



The key of F Major has 1 flat, B-flat.

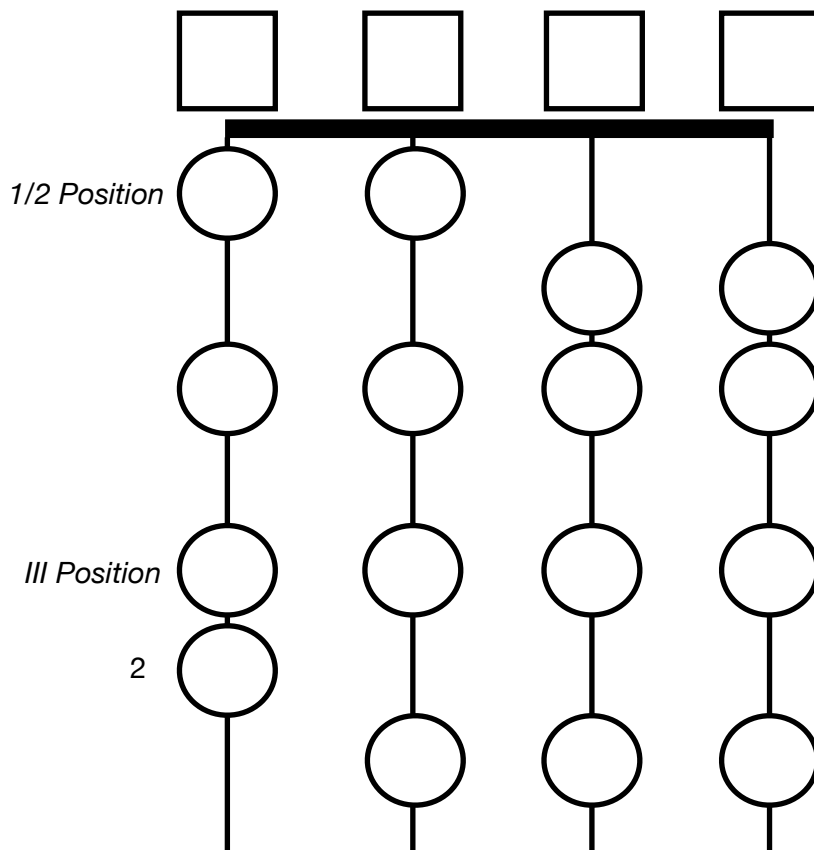

Fingerboard Geography for Double Bass

Key of B-Flat Major

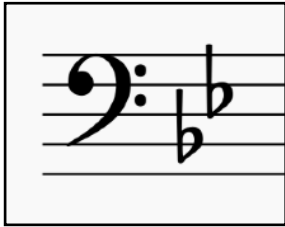

The key of B-flat Major has 2 flats: B-flat and E-flat. (*Open E-string is not allowed!*)

1/2 Position

3rd Position

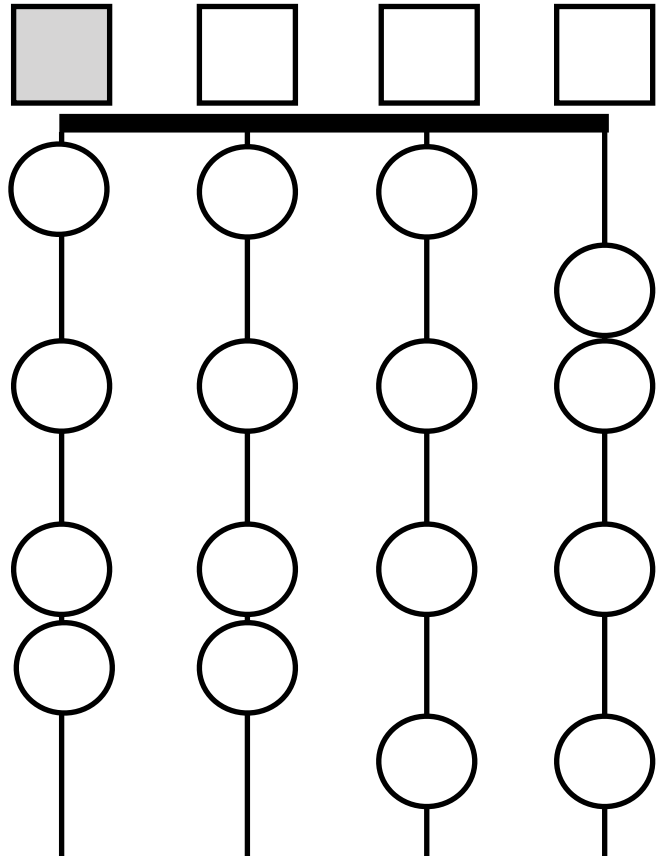

Key of A Major



The key of A Major has 3 sharps: F#, C#, and G#.

1st Position

3rd Position

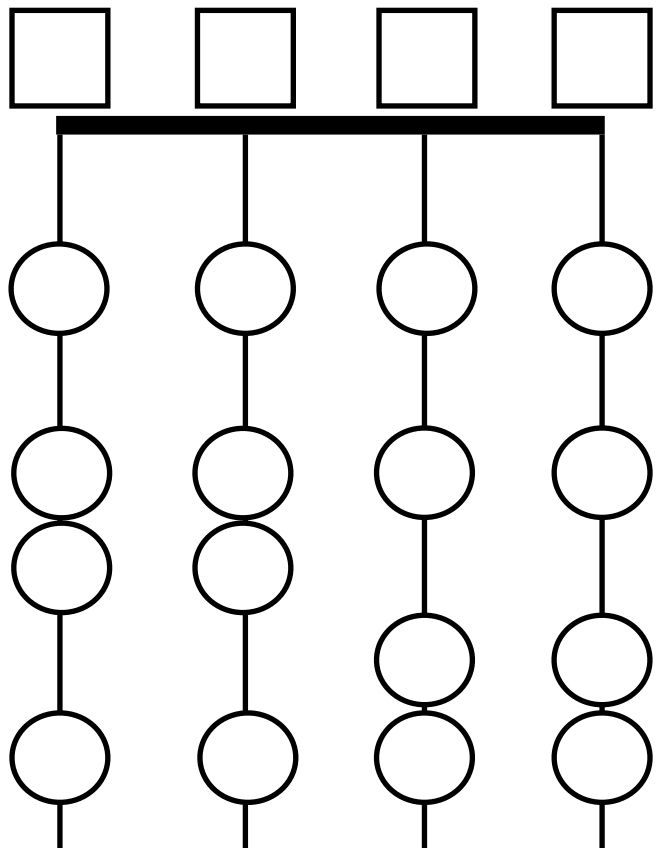

Fingerboard Geography for Double Bass

Key of E-flat Major



The key of E-flat Major has 3 flats: B-flat, E-flat, and A-flat. (Open E and A strings are not allowed!)

1/2 Position

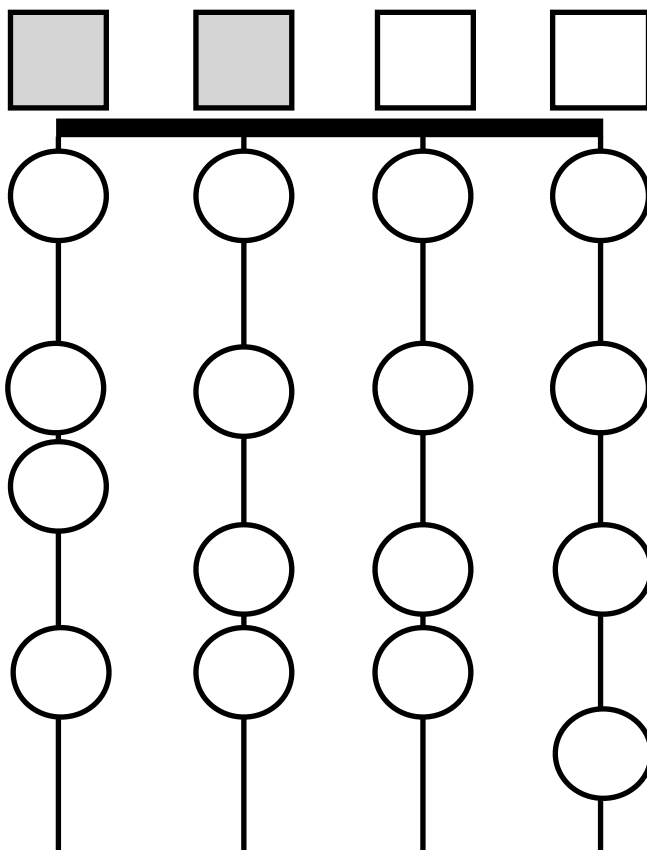

Key of E Major



The key of E Major has 4 sharps: F#, C#, G#, and D#. (Open D string is not allowed!)

1st Position

3rd Position

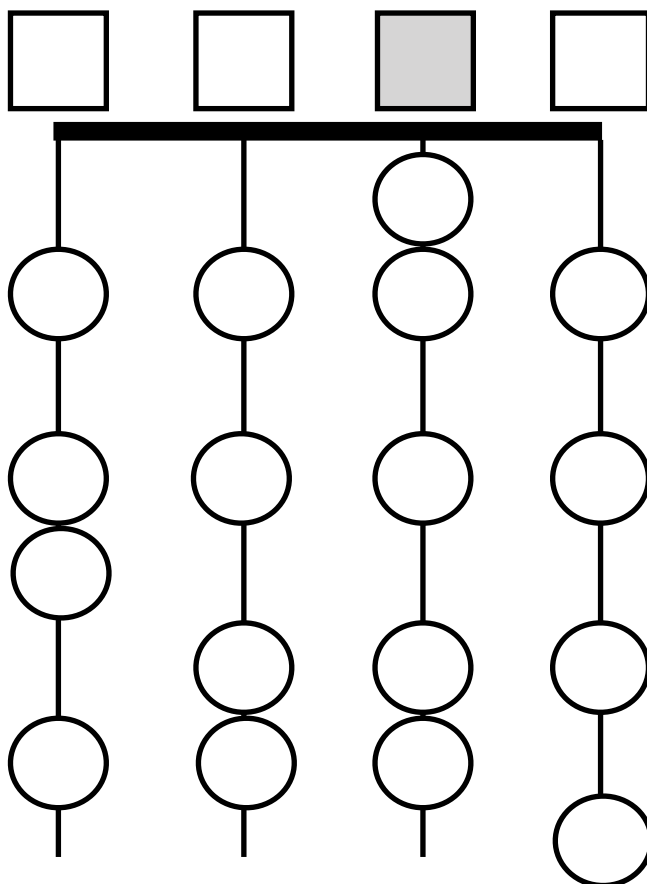

Fingerboard Geography for Double Bass

Key of A-Flat Major

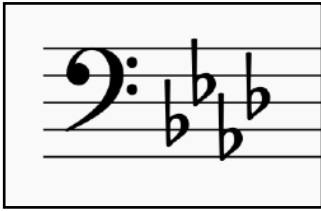

1/2 Position

The key of A-flat Major has 4 flats: B-flat, E-flat, A-flat and D-flat. (Open E, A, and D strings are not allowed!)

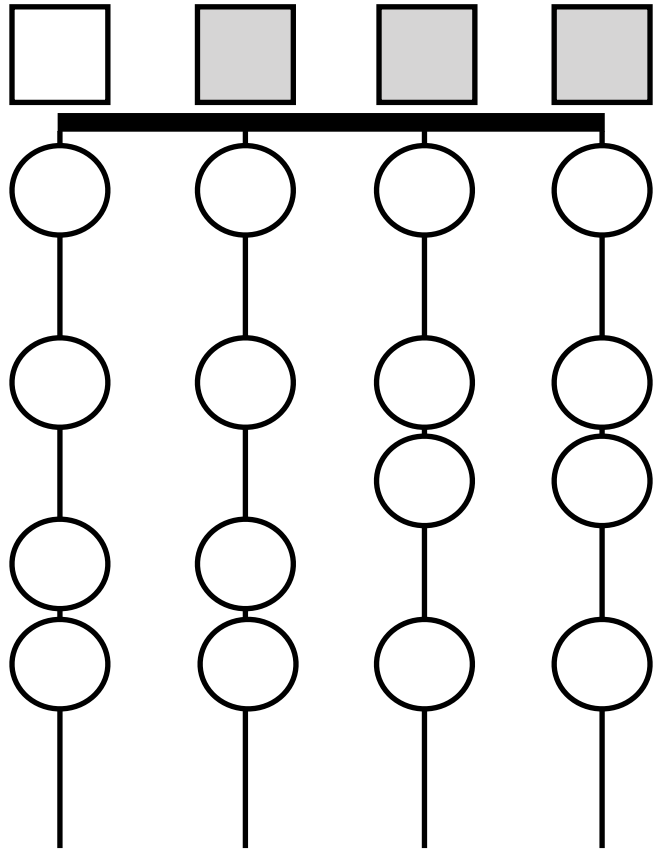

Chromatics

Fill in ALL of the notes on your fingerboard, in half-steps.

Remember the natural half-steps: E-F and B-C.

